

**American Changer Corp.**  
**1400 NW 65<sup>th</sup> Place**  
**Ft. Lauderdale, FL 33309**

*Internet Address:* **www.americanchanger.com**  
*Service or Parts Questions? e-mail:* **service@americanchanger.com**

# DOUBLE PHONE CARD DISPENSER OPERATIONS MANUAL SERIES AC502

**TOLL FREE!**  
**Parts & Service:(888)741-9840**  
**Sales:(800)741-9840**  
**Fax:(954)917-5204**

### Table of Contents

#### SECTION A: SET-UP & INSTALLATION

Uncrating & Set-up \_\_\_\_\_ 3  
**Filling the Card Dispenser \_\_\_\_\_ 3**  
 Setting up card pricing \_\_\_\_\_ 3  
 Fuses \_\_\_\_\_ 4  
 Functional Descriptions \_\_\_\_\_ 4-5  
 Indicator Lights \_\_\_\_\_ 5  
 Wiring definitions \_\_\_\_\_ 5  
**Adjusting the card dispenser card size for other thickness cards \_\_\_\_\_ 6-8**

#### SECTION B: BILL ACCEPTOR

**INFORMATION \_\_\_\_\_ 10-16**  
**Bill acceptor error codes \_\_\_\_\_ 5**  
 Clearing a bill jam \_\_\_\_\_ 11  
 Cleaning the bill acceptor \_\_\_\_\_ 11  
 Setting the bills accepted \_\_\_\_\_ 12

#### SECTION C: TROUBLESHOOTING

**INFORMATION \_\_\_\_\_ 17-19**  
 Troubleshooting Guide \_\_\_\_\_ 17  
 Technical Flow Diagram \_\_\_\_\_ 18-19

#### SECTION D: PARTS LISTS

Cabinet Parts Breakdown \_\_\_\_\_ 20  
 Parts Bill Acceptor \_\_\_\_\_ 21-24  
 Parts CD200 card dispenser \_\_\_\_\_ 25

*CoinCo branches and Service centers are on the back cover of this manual.*

### Specifications

Operating voltage	120 VAC +10/-15 %
Power consumpt.(controller only, add card dispenser and validator) 10w	
Operating temperature	32 - 130 degrees Fahrenheit
Interface to Hoppers	24vdc & 12vdc 1.5 amps max.
Interface to Validators	120vac .5 amps max.

### Warranty

CoinCo BA30B - BA30BB Validator  
 The CoinCo BA30B BA30BB Dollar Bill Validator is warranted for two years from date of purchase.

#### COVERED

¥ Defect in workmanship or material.

#### NOT COVERED

- ¥ Damage caused by physical abuse.
- ¥ Misapplication.
- ¥ Vandalism.
- ¥ End users attempt, on his own to repair item.
- ¥ Cleaning maintenance.

**It is the End User's responsibility to follow cleaning maintenance procedure outline on pages 14-15. Any unit coming in for repair requiring only a cleaning will be charged a flat rate of \$65.00 plus shipping and handling.**

### Dispensing System and Logic Board

The dispenser and logic board is warranted for one year from date of purchase.

#### COVERED

¥ Defects caused by material or workmanship.

#### NOT COVERED

- ¥ Damage caused by physical abuse.
- ¥ Misapplication.
- ¥ Vandalism.
- ¥ End Users attempt, on his/her own to repair.

**A Return material authorization number (RMA#) must be obtained before returning a unit for repair . A copy of invoices must accompany any and all warrantee work.**

### **Attention Please:**

American Changer is now building in a Surge Suppressor on every main logic board made after September 1<sup>st</sup>, 1998. This will help eliminate power related noise problems for our customers. It will not protect you from large voltage spikes or lightning strikes over 150VAC.

If this is a concern for your area of business, we recommend purchasing a surge protector locally

**NOTE: A POWER STRIP IS NOT A SURGE PROTECTOR.**

**Thank You,  
American Changer Corp.  
(888) 741-9840**

**UNCRATING AND SET-UP**

Remove your Series AC502 phone card machine from the shipping box. Open the door. **(The T-handle is the screw-in type and therefor, must be turned at least 10 times counter-clockwise until it opens.)** Inspect for any connectors or components that may have been dislodged during shipping. The lock and keys for your phone card machine will be inside the manila envelope along with this manual. To install the locks, insert the cylinders into the round hole in the middle of the T-handle and push until they stop. Now turn the key and lock until you hear it "snap." Turn the key counter-clockwise ¼ turn and remove the keys.

**NOTE: The only way to get a duplicate set of keys made is to save the red tag that comes between the keys.  
This ID # starts with "ACC \_\_\_\_\_".**

**TEST:**  
Before permanently installing the phone card machine, do a functional test to verify that there is no shipping damage to your new phone card machine(s). Extend the power cord through the hole in the back of the phone card machine or the bottom and plug it into a **grounded 120vac outlet. The dip switches are already set to dispense a \$10.00 card. The dollar bill acceptor is ready to accept \$1-\$5-\$10-\$20**

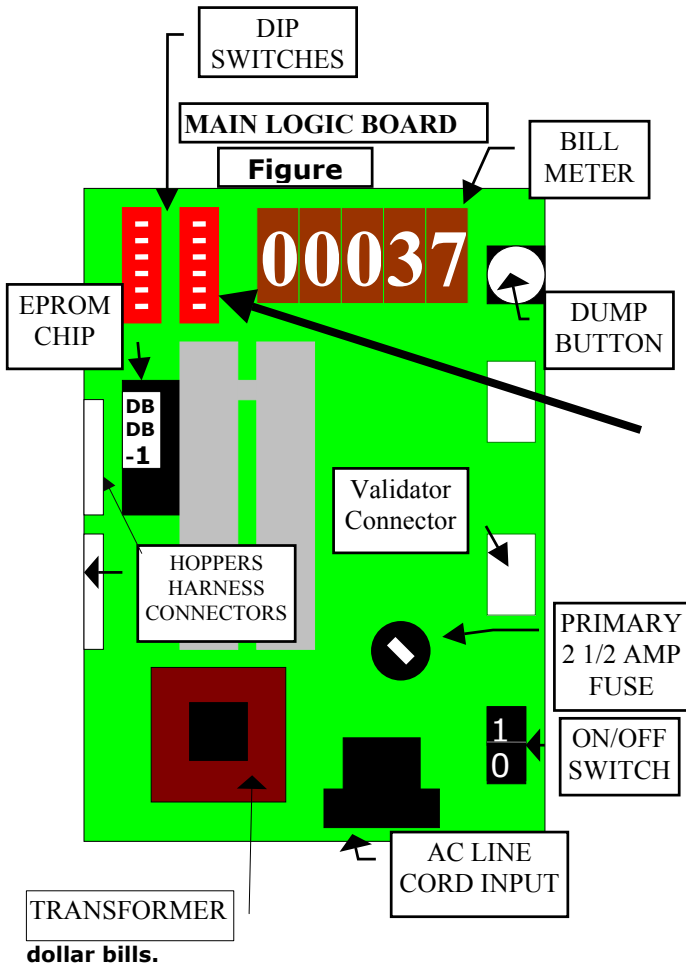

**Fill the card dispenser with at least 3 cards.**

On the main logic board turn the switch on the bottom right corner "ON". (SEE FIG. 1 ON PG.3) The rocker switch has a "1" and "0" printed on it. When the "1" is pressed down the phone card machine is "ON".

**FILLING THE HOPPER**

When the card dispenser has less than 1 card left in it the red "Empty" LED will light on the front of the phone card machine. If you have disconnected your LED make sure the orange wire is going to the terminal on the LED that has the red positive mark next to it. Whenever the "Empty" LED is "ON" the validator is disabled and it will no longer accept bills.

1. Turn OFF the power on the main logic board.
2. Cut the tie-wrap holding the "I" weight and slide it out of the dispenser through the opening on the top.
3. Place the 3 phone cards face up into the opening. (Make sure they are flat and stacked neatly.)
4. Fill up the rest of the dispenser with the remaining cards.
5. Place the "I" weight on top of the cards.
6. Turn "ON" the power switch. The "Empty" LED is now off and the dollar bill acceptor is ready to accept bills.

**SETTING THE CARD PRICE**

The AC502 phone card machine is capable of dispensing from a \$1 to \$127 card in \$1 increments. Setting the cards out per dollar is controlled by which Dipswitches turned "ON." (Refer to figure 1 for their location.) For example, switches #2 & #4 on the left dip are "ON"; therefore the card price is \$10 per card for the left dispenser. Switches #3 & #5 on the right dip are "ON"; therefore the card price is \$20 per card for the right dispenser.

The following table shows how to set the dip switches for the most common card costs.

"ON"	" COST PER CARD"
#1 & #3 _____	\$5
#2 & #4 _____	\$10
#1 & #2 & #3 & #4 _____	\$15
#3 & #5 _____	\$20
#1 & #4 & #5 _____	\$25
#2 & #5 & #6 _____	\$50

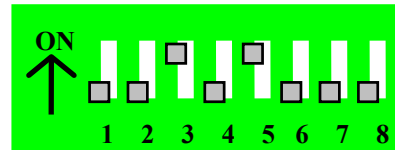

RIGHT BANK DIPS  
(FIGURE 2)

**(THIS IS NOT THE DIPSWITCH BANK FOR SETTING THE BILL DENOMINATIONS. (For those dip switches go to page 10.)**

## FUSE

**High voltage fuse:** This is the primary transformer AC fuse for the main logic board and the validator. Any direct short of the Transformer or validator will cause this fuse to blow. Replace this fuse with a 2-1/2 amp AS fuse only. **REPLACING THIS FUSE WITH ANYTHING OTHER THAN A 2 1/2 AMP "AS" MAY RESULT IN A FIRE OR AN UNSAFE WORKING CONDITION!!** (See fig. 1 for location of this fuse.)

### Functional Description of the Series AC502 Changer

*To follow along with this walk-through of your phone card machine, fill the card dispenser with cards and turn the phone card machine on.*

1. When power is applied the validator will cycle twice. The out-of-service LED flashes then goes out. The green LED on the main logic board comes on steady, and the decimal point on the red LED display on the main logic board will light then go off then flicker on once per second in the standby mode.
2. During the power-up mode the main logic board relay clicks twice enabling power (120vac) to the validator. When this relay is not enabled it routes 12vdc ground to the out-of-service LED. Without power to the validator, the phone card machine cannot accept bills. Since we are not in the "Empty" mode, the red LED on the validator logic board is on steady.
3. When a bill is inserted into the validator bill slot, the bill will be pulled inside. The validator then compares what the bill looks like to its memory. After the bill is validated it grounds the 5vdc lines causing a pulse along the yellow and blue validator harness wires to pins 5 and 15 of the main logic board. Each pulse stands for the amount of the denomination validated. (i.e. 1 pulse for \$1, 5 pulses for \$5).
4. The 5vdc pulse then travels from pins 5 and 15 to the EPROM chip (ver. D-DEBT "G") pin #21. The EPROM updates the meter chip (U5) (one pulse per denomination validated). The EPROM also divides the bill pulse by the DipSwitch settings (The EPROM reads the DipSwitch settings during the power up mode and stores them into memory.)
5. The EPROM then sends the card dispenser pulses out pin #17 or #18 to pin 7 of the red 12-pin card dispenser plug. This pulse travel through brown wire of the card dispenser wire harness to the card dispenser pin 8.
6. The card dispenser turns itself on with the first card dispenser pulse. The card dispenser counts the card dispenser pulses sent from the EPROM while dispensing the card at the same time. When the amount of card

dispenser pulses in equals the cards dispensed through the card counting optical sensor the EPROM turns the card dispenser off.

7. The Changer returns to the standby mode with the decimal point on the red LED display flashing once per second until another bill is inserted.

**NOTE: THE METER ON THE MAIN LOGIC BOARD CANNOT BE RESET TO ZERO!!!**

### Functional Descriptions of Out-of-Service Conditions

*Out-of-Service conditions occur for the Series AC502 phone card machine for the following reasons: low cards, card dispenser fault error, validator fault, or a blown fuse.*

1. **Blown Fuse:** an AC power spike in line voltage or a bad transformer on the main logic board can cause A blown fuse on the main logic board. If either fuse blows the indication is the green LED on the main logic board will not light.
  - A. Replace the fuse. If the green LED now lights then there was a spike.
  - B. If it does not and the fuse blows again the power transformer is shorted. To test the transformer use a voltmeter set for ohms and measure across the primary (40ohms) and the secondary (1.5ohms).
2. **Hopper Fault:** A card dispenser fault can either be a jammed card dispenser, a blocked card counting optic or a bad dispenser logic board.
  1. Indications for a jammed dispenser, bad dispenser logic board or blocked card counting optic are the phone card machine's "empty LED is ON and the decimal point on the red LED display on the main logic board is on steady.
  2. At this point the three options open are to attempt repair on your own, call your distributor, or return the card dispenser to American Changer.
3. **Validator Fault:** When a validator fault occurs the validator's EPROM shuts down the validator and flashes an error code via the red LED on the validator logic board. When there is no error this LED is on steady. The validator only gives bill pulses to the main logic board so the main board never knows if the validator isn't functioning. Therefore the out-of-service-LED will not light. (See page 6 for validator error codes.)
4. **Low Cards:** The low card condition is probably the most common fault. The EPROM

on the main logic board is constantly checking for low cards in the card dispenser. This is done with a low current 5vdc signal on pin #3 of the card dispenser output connector. The voltage then travels down the card dispenser wire harness on the white wire to pin #7 of card dispenser plug. The signal is applied to micro switch. The 5v travels through the switch. It then goes through the black wire in the card dispenser harness to pin #10 on the main logic board.

- A. Check continuity, (0 ohms) resistance, from pins 3 (white) and 10 (black) of the red card dispenser harness. Make sure the card dispenser is full and the phone card machine turned off.
  1. If the continuity is 0 ohms, replace the main logic board.
  1. If the continuity is infinity, then replace the dispenser's switch.

### **Indicator Lights**

#### **Main Logic Board:**

1. Green LED on: AC power applied to the logic board. All fuses are good.
2. Red LED
  - A. Heartbeat - 5 and 12vdc present. The phone card machine is in standby waiting for a bill pulse.
  - B. On Steady - Out of service, card dispenser error detected.

#### **Validator logic board:**

1. Red LED
  - A. On Steady - Standby Mode, waiting for bill insertion.
  - B. Flashing - Error mode, go to page for error code information.
  - C. Off - The phone card machine "Empty" LED is lit.

### **WIRE HARNESS COLOR AND DEFINITIONS**

#### **Validator harness:**

- Red - Switched Hot 120VAC.
- White - Neutral 120VAC.
- Black - 120VAC Low current validator enable.
- Yellow - +5vdc credit pulse line.
- Blue - -5vdc credit pulse line.
- Orange - +12vdc Empty LED.
- Brown - -12vdc Empty LED.

#### **Hopper Harness**

- Gray - Coin counting optic status line.
- White - Low coin sense (+5vdc).
- Green - Coin counting optic pay out feedback line.
- Yellow - Raw sensor output line.
- Purple - Hopper pay out line from main logic board (+),
- Brown - Hopper pay out line from main logic board (-).
- Red - +12vdc logic board supply voltage.
- Black(s) - 12v, 24v low coin sense ground.
- Orange - +24vdc Motor supply voltage.

### **CoinCo BA30 Flash Codes**

Flash codes 1-6 may appear during normal servicing of the BA30. To access flash codes 7-18, open bill box lid and remove power from the BA30 for 10 seconds. Reapply power to BA30 with bill box lid open. Flash codes 7-18 will now appear for respective error or condition detected in the BA30. If more than one error or condition exists, the lower number flash code will appear until its respective error or condition is corrected. The left and right sensors referenced below are given viewing the BA30 from the front.

#### # of Flashes      Description of Flash Codes

- |   |   |
|---|---|
| 1 | Bill box full                           |
| 2 | Bill box lid is open or bill box is off |
| 3 | Check bill path                         |
| 4 | All bill accept switches are off        |
| 5 | Bill jam or sensor error                |
| 6 | Stacker motor/home sensor               |
| 7 | Transport motor/encoder sensor          |

*For higher error codes or any other service problems call our service department toll free at:*

**(888) 741-8940**

### **ASAHI SEIKO CD200 CARD DISPENSER :**

This section of the manual will guide you through the procedure for changing the card thickness adjustment on the card dispenser. As an example, we will adjust from a 0.010" thick card to a 0.034" thick card.

## 4. Adjusting Your Card Dispenser

The adjustments consist of the following:

- Adjustment of the distance between the counter turning roller (CTR), feeding roller (FR) and the adjusting plate.
- Tension adjustment on the drive belt.
- Adjustment of the shutter section.

We are using the CD-200 as an example!

1

This is going to be a long section. We'll go slow and incorporate diagrams to make it easier....

### 4.1 Distance Adjustment

Between the rollers and the position of the adjusting plate.

1) Loosen the four screws holding the guide bracket, this will enlarge the vertical adjusting distance.

2) Loosen the screw of the tension lever, pull the lever to release the tension on the belt.

First, loosen the two socket head screws on each side to extent that the adjusting plate can be moved.

As shown in Fig. 3, the shaft of the CTR is supported at both ends by the adjusting plate. Therefore, the adjusting plate on both ends of the CTR must be free to enable adjustment of the distance between the CTR (Counter Turning Roller) and the FR (Feeding Roller).

Note: Large Adjustments (.010" to .034:")  
Adjust the Jack Screws by turning them clockwise 1.5 turns. This will increase the gap between the CTR and the FR to accommodate a .034" thick card from the .010" card. Make sure the same amount of turns is evenly applied to all four of the Jack Screws.

2

For easy viewing of the hole, remove the shutter's support bar and pull the shutter UP...

FIGURE 4

When you are looking at the card dispenser straight on, you will see the motor and above that the rollers. Right here (when the shutter is lifted) you will see the card passage between the CTR and the FR. These rollers are adjusted to accommodate a thicker card.

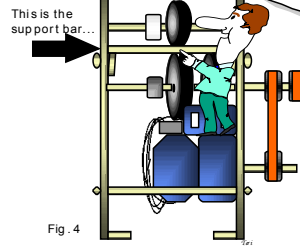

Fig. 4

NOTE: Make sure the card sliding through is not being restricted by the guide bracket teeth. When adjusting to a card thickness (.010" to .034", a significant change) - adjustments will have to be made to the CTR as well as the guide bracket.

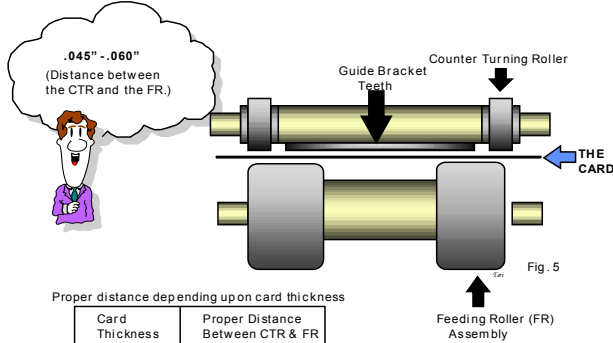
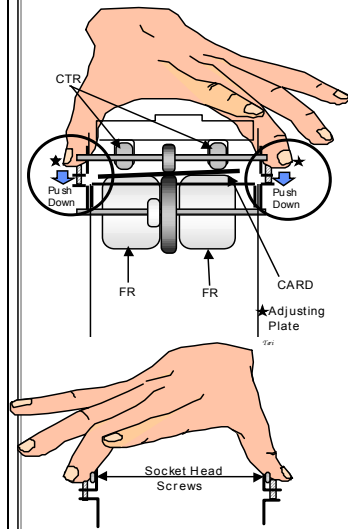

Fig. 5

Proper distance depending upon card thickness

Card Thickness	Proper Distance Between CTR & FR
.010"	.014" to .016"
.020"	.025" to .031"
.030"	.040" to .050"
.034"	.045" to .060"

NOTE: Ideally the gap distance between the CTR and the FR is 1.5 time the card thickness!



DO A QUICK CHECK!

By inserting a card and sliding it through the rollers, make sure to apply pressure and hold down both sides of the adjusting plate with your hands. The card should slide through without interfering with the CTR. Double check by stacking two cards together and go through the same process. The total thickness of the combined cards SHOULD be thick enough to interfere with the CTR. Therefore, the CTR will be able to push the second card back into the cartridge and avoid double dispensing.

After proper gap adjustment has been achieved, the CTR can be locked into it's position by tightening the socket head cap screws on both sides of the unit. Reminder: Make sure to apply and keep pressure down on both sides of the adjusting plate with your hands during this process.

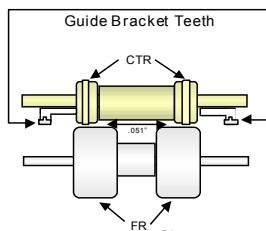

Next, make proper adjustments to the guide bracket. To make the adjustments align the Guide Bracket Teeth the same gap distance as the CTR. Both the CTR and the Guide Bracket Teeth should have the same gap distance from the FR.

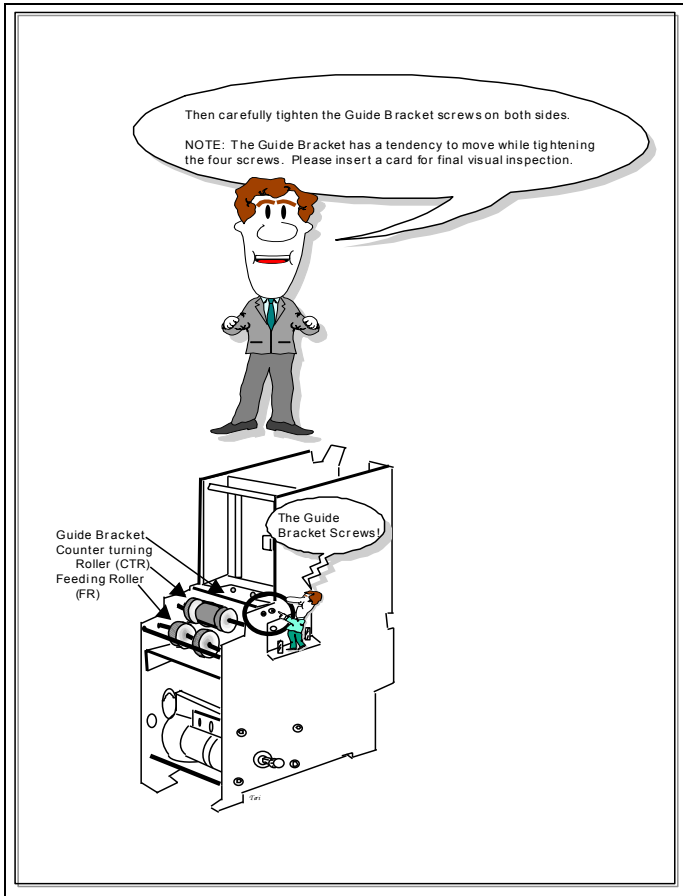

5

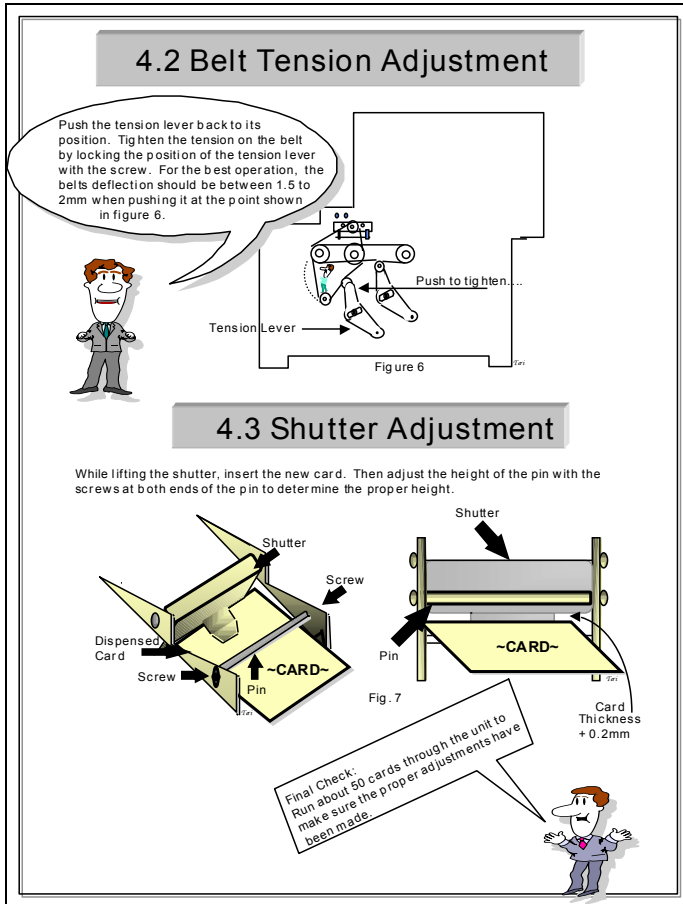

6



# MAINTENANCE

## 5. Maintenance

Ideally, maintenance should be performed after every 10,000 cards have dispensed....

This is the instrument you will be using when you clean your card dispenser. Yes, it is a cotton swab! This nifty little invention let's you get into those tight little places and clean to your heart's content.

I can't believe he forgot the cloth..... You will be needing a small piece of cloth to wipe off the opto-sensor once every two months

**VIEW OF THE DISPENSER WITH THE SHUTTER REMOVED...LOOKING DOWN FROM THE TOP.....**

Fig. 9

Dip the cotton swab into rubbing alcohol and clean the rollers as they are turning. Wipe down the inside walls and base plate with a piece of cloth dipped and wrung out (not sopping wet).

1

This is the clutch roller, we are looking down inside the dispenser, where the cards are stacked!

Rubbing Alcohol

Dispensing Card

Fig. 10

Rain drops are falling on my head....

Now you will want to clean the clutch roller. This roller turns freely. Clean it thoroughly. And let the alcohol dry before restocking the dispenser with cards.

2

# MAG BILL ACCEPTOR

Operation and Service Manual



## COINCO MAG50BAB VALIDATOR SECTION

	<b>PAGE</b>
Removing the Bill Box_____	<u>11</u>
Clearing a bill jam_____	<u>11</u>
Setting the bill types accepted_____	<u>12</u>
Cleaning the sensors _____	<u>14</u>
Cleaning a salted unit_____	<u>15</u>
Replacing the belts_____	<u>16</u>

### Removing the bill box.

To remove the 1000 bill stacker from the CoinCo validator follow the picture below.

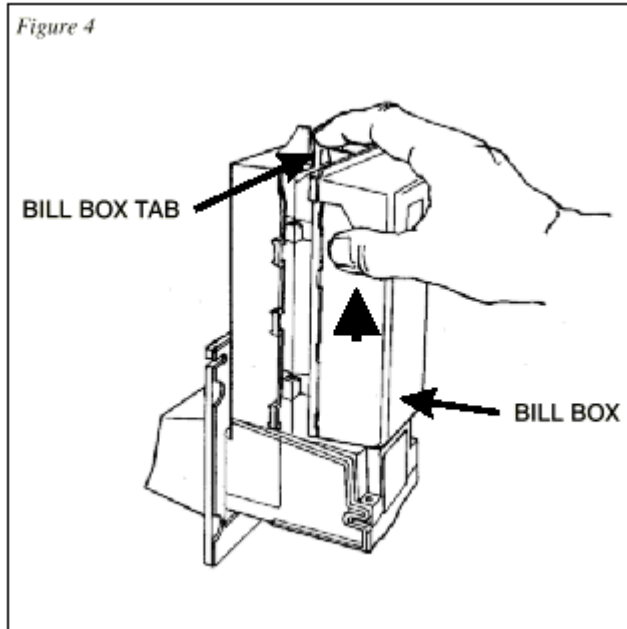

### REMOVING A BILL JAM

From time to time a foreign object or ripped bill will become caught in the validator. Follow the picture below to remove the item.

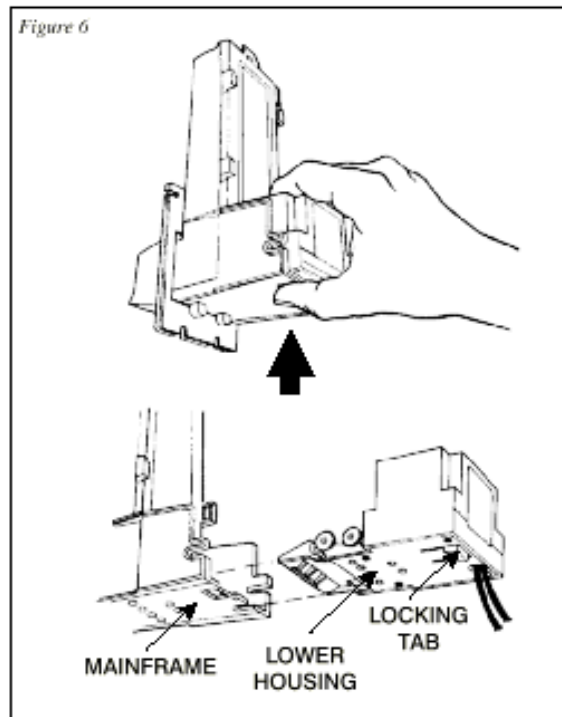

## SETTING THE BILL ACCEPT DIP SWITCHES

*Figure 1*

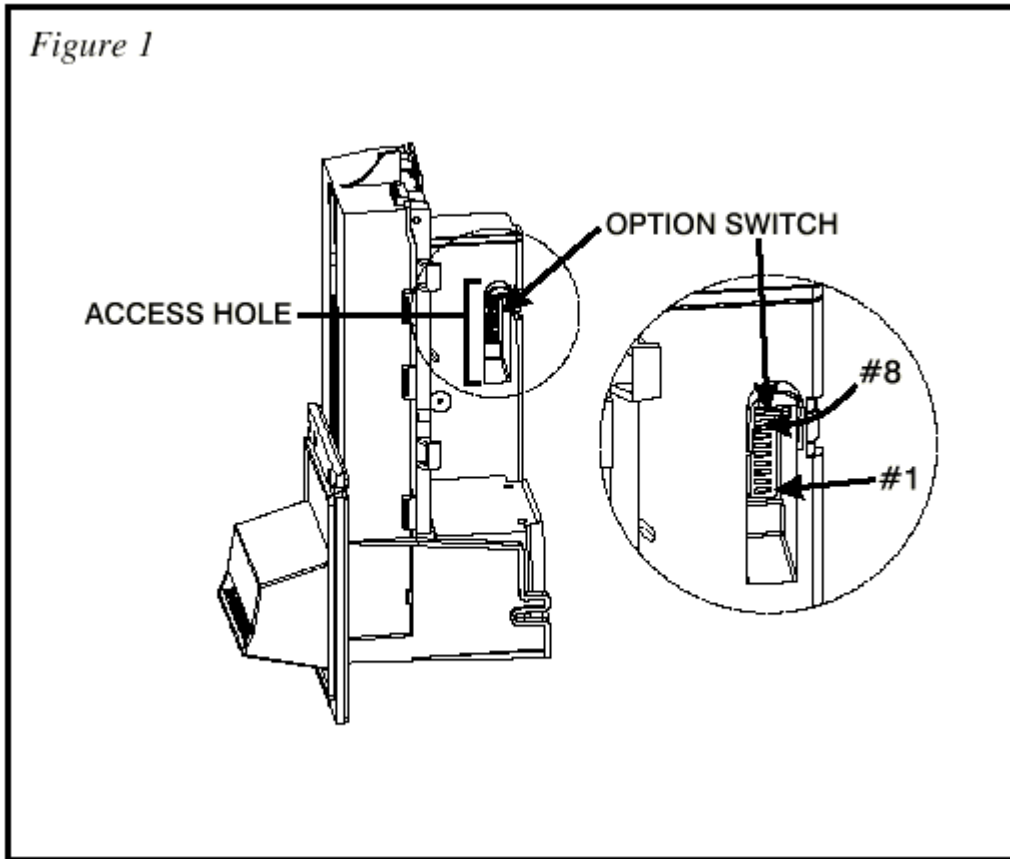

SWITCH	ON	0
1	High Security	Standard Acceptance
2	Accepts bills in one directions only (face up, green seal first)	Accepts bills in both directions (face up)
3	Serial or Parallel Interface	Pulse Interface
4	\$20 Accept	\$20 Reject
5	\$10 Accept	\$10 Reject
6	\$5 Accept	\$5 Reject
7	\$2 Accept	\$2 Reject
8	\$1 Accept	\$1 Reject

*Figure 2*

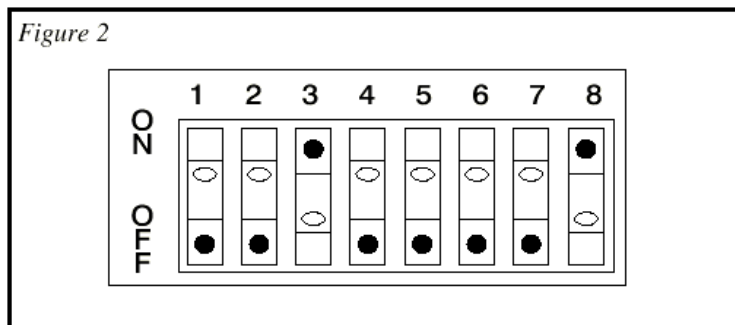
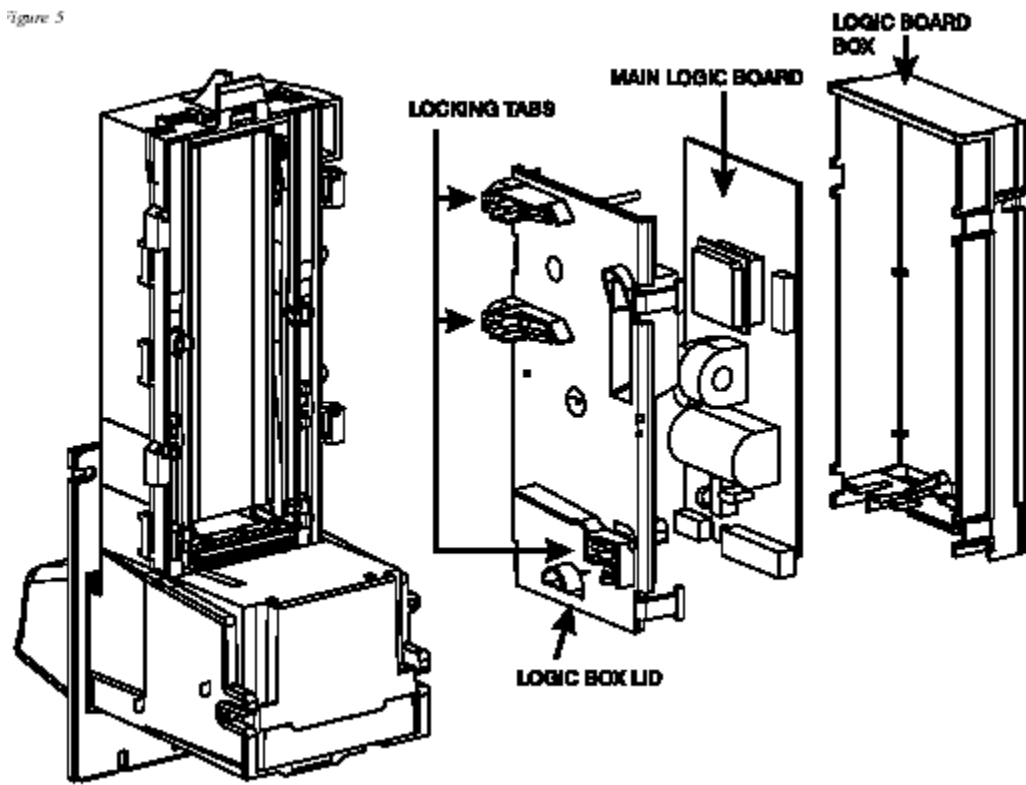
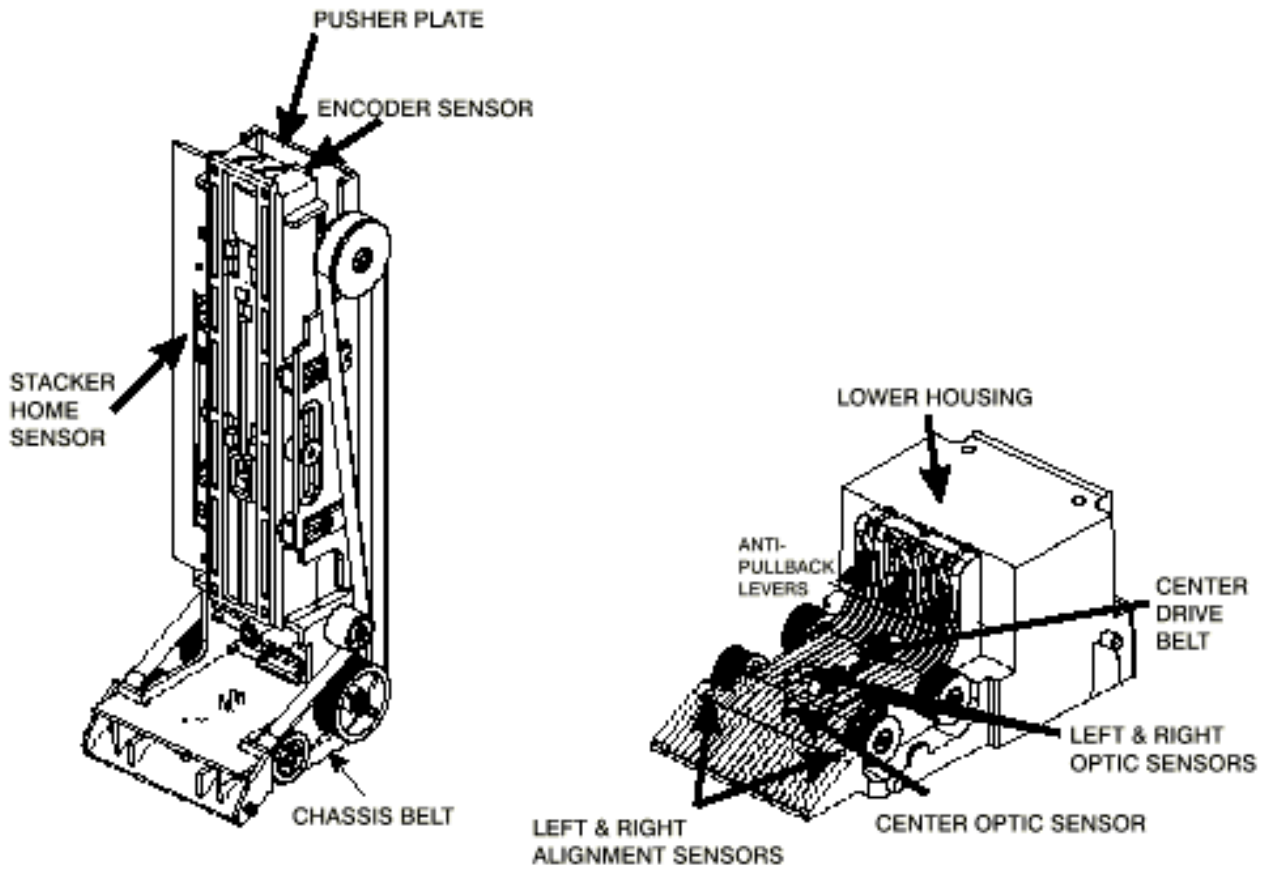

Figure 5



## CLEANING THE BILL VALIDATOR

Refer to the pictures and the procedure on the next page to clean the bill validator every 4-6 months.



**BA30B (B) CLEANING IF ANY OF THESE PROCEDURES ARE PERFORMED TO YOUR VALIDATOR AFTER IT IS RETURNED UNDER A WARRANTY REPLACEMENT, YOU WILL BE SUBJECTED TO A \$35.00 LABOR FEE.**

**BA30B CLEANING AND MAINTENANCE:**

**Note:** *Petroleum-based cleaners and freon-based propellants can damage plastic and some electronic components. Scouring pads and stiff brushes may harm the protective conformal coating on the circuit boards and can mar the plastic. These items should never be used when cleaning the BA30 bill acceptor.*

**The BA30 should be cleaned every 7,000 bills or every 4 -6 months (or as needed, depending on the environmental conditions of the location). Dust can be removed with a soft brush or cloth or it can be blown out using compressed air.**

**Procedure:**

1. Disconnect power from the bill acceptor.
2. Remove the bill box and use a soft cloth to wipe the dust from around the intermediate frame and stacker plate.
3. Remove the lower track.
4. Using compressed air or a soft brush, blow or brush the dust off of the optic sensors and out of the recessed sensor openings.
5. Remove dust from around the belts and wheels on the lower housing and the sensors on the upper sensor board. The upper sensors are located directly above the lower housing sensor when the lower housing is installed.
6. The bill path can be cleaned to remove further dirt and oil using a soft cloth moistened with a mild soap and water solution.
7. Clean the magnetic head using a swab and isopropyl alcohol.
8. Once the lower housing is dry, place it back into the mainframe so that the tab on the bottom locks into place.
9. Blow the dust out of the encoder wheel and its sensors. (It may be necessary to extend the stacker plate to access the encoder wheel. Supplying power to the unit momentarily can do this, so that the stacker plate extends.)
10. Remove dust from the transport belt areas and from any other places of build up.
11. Remount the bill box.
12. Apply power and insert bills to verify that the unit is functioning properly.

**BA30 CLEANING PROCEDURE FOR SALT WATER POLLUTED UNITS:**

**Note:** *Petroleum-based cleaners and freon-based propellants can damage plastic and some electronic components. Scouring pads and stiff brushes may harm the protective conformal coating on the circuit boards and can mar the plastic. These items should never be used when cleaning the BA30 bill acceptor.*

**Procedure:**

1. Remove power from the bill acceptor.
2. Remove the bill acceptor from the vending machine.
3. Open the bill box lid and verify that the stacker plate is in the stand-by/home position. If it is not in the home position, apply power and observe that the stacker plate returns home.

**Warning:** *If moisture is present, allow the unit to dry thoroughly before applying power to avoid possible shock hazard. If the stacker plate does not return to the home position, remove power and carefully remove the bill box to avoid damaging the bill box and/or stacker plate.*

4. Remove the lower housing.

5. Remove the bottom cover from the lower housing.
6. Run hot water (1101/4-1401/4F) over the lower housing from the top and bottom. Using a soft brush, gently clean any residual salt. Use a soft absorbent cloth to clean any residue off the lower housing. If the transformer gets wet, allow the unit to dry for 24 hours before applying power.
7. Remove the front mask. Using hot water and a soft brush, clean the front mask, upper sensor board, main frame anti-pullback levers and position sensor mount.

*Caution: The motors are not protected from water, therefore the unit must be held in a manner that prevents water from running over the intermediate frame crossbar.*

8. Remove the position sensor cover on the crossbar and carefully lift the LED from its mount. (Early models only.)

*Caution: Protective coating on the LED leads should not be damaged. Clean all salt residue from the mount, sensor hole and detector area.*

*The detector can be seen through the sensor hole, and is located in the chassis. Replace the position sensor cover. (Early models only.)*

9. Verify that the anti-pullback levers move freely and that the spring returns them to their open position.
10. Allow the unit to dry thoroughly.
11. Clean the magnetic head using a swab and isopropyl alcohol.
12. Replace the front mask
13. Replace the lower housing cover.
14. Replace the lower housing into the main frame.
15. Remount the bill box.
16. Apply power and insert bills to verify that the unit is functioning properly.

**6 OR 7 ERROR CODE FLASHES**

*The cleaning procedure for this common occurrence is listed below. Just follow these steps.*

1. If this code has occurred on a new machine or one that the validators DIP switches were just changed, Ensure that all the white plugs on the side of the validator board away from the red LED are plugged in securely.
2. Remove the bill box.
3. Turn the Changer ON then OFF in an attempt to stop the metal push plate so that it COASTS into the fully outward position.
4. Using an air compressor or a can of compressed air blow out the area behind the push plate until it is completely free of all dust and lint.
5. Turn the changer power back on so that the push plate returns to the inward position. If the same error code persists, repeat steps 1 - 3 concentrating on the top center area behind the plate.
6. Replace the bill box.

## REPLACING THE BELTS

Every 2-3 years the belts on the CoinCo will wear out. To replace them, remove the validator components down to the picture show. Refer to the parts diagram at the end of the manual for help getting to this point.

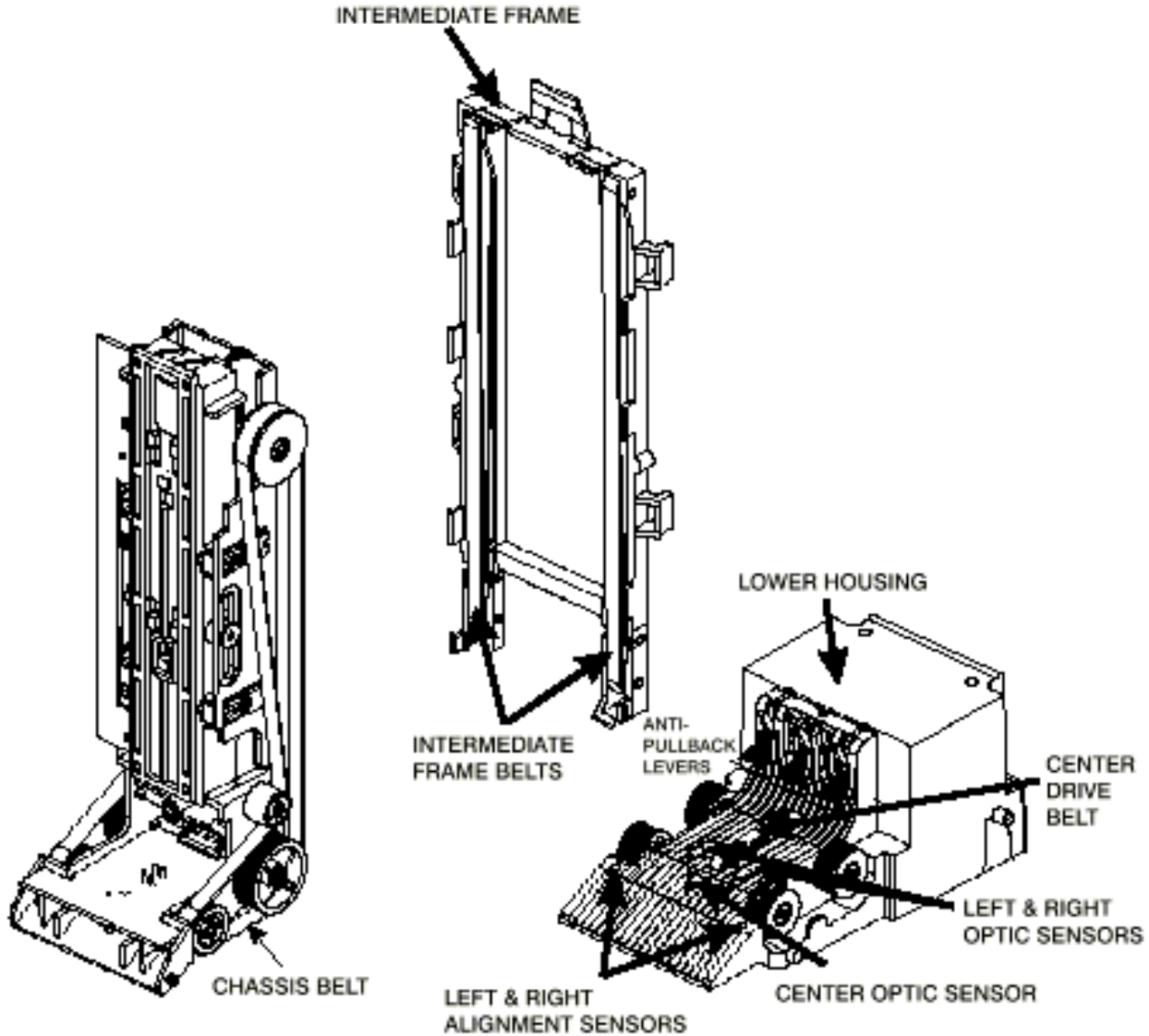



# TECHNICAL FLOW DIAGRAM FOR THE AC502 SERIES

**NOTE:** Before starting this procedure ensure the phone card machine is plugged in, the ON/OFF switch is on, the card dispenser is full of cards, and all wire harnesses are connected securely and correctly.

*The wires exiting the red connectors should point away from the board!*

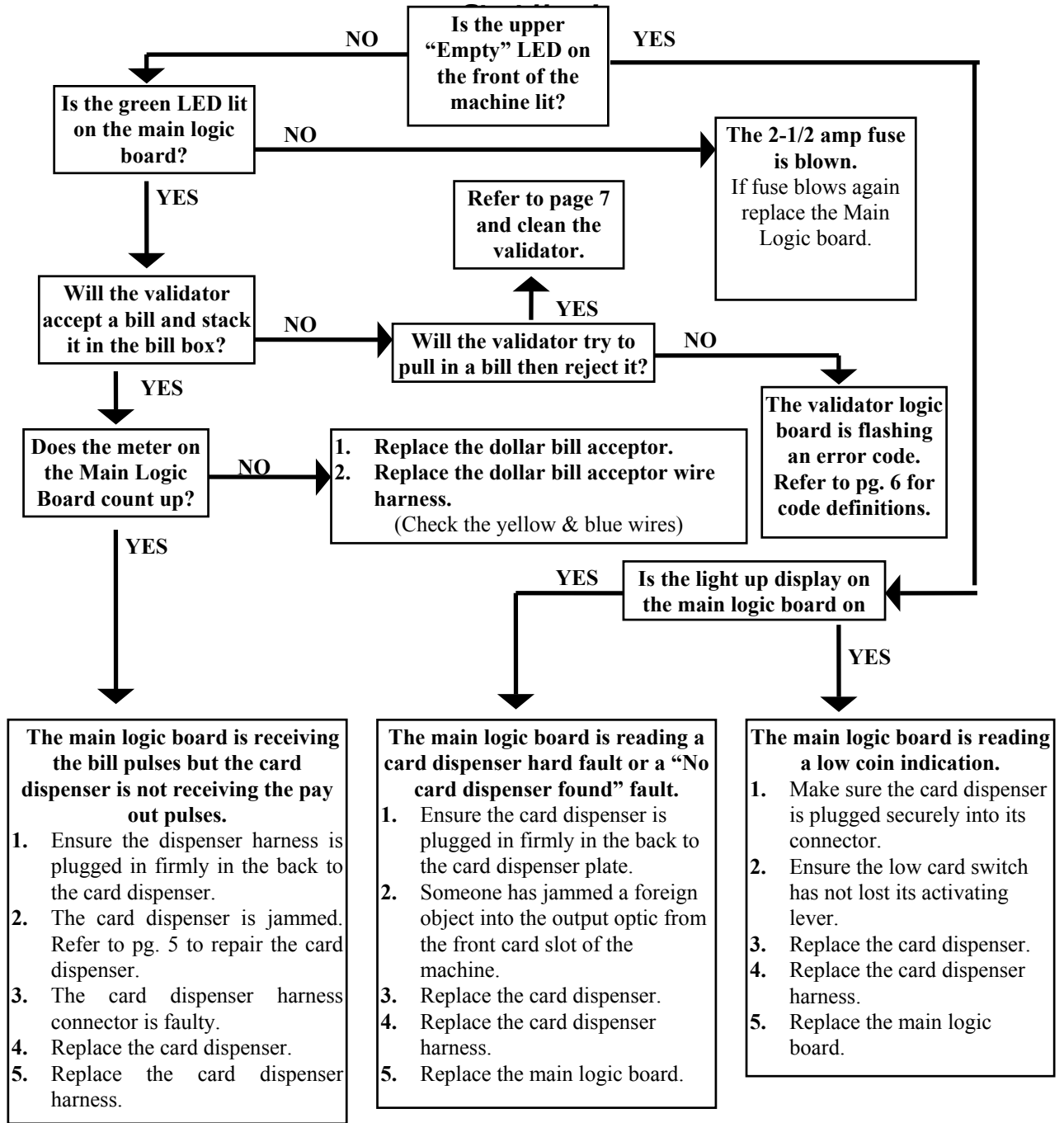

**For more detailed trouble shooting information proceed to the next section!  
FOR TECHNICAL SERVICE OR TO OBTAIN A RETURN AUTHORIZATION  
NUMBER CALL (888) 741-9840**

**ANY REPAIR RETURNED WITHOUT A RETURN AUTH. # WILL BE REFUSED!**

## TROUBLESHOOTING GUIDE

**TO USE THE TROUBLESHOOTING GUIDE, MATCH UP THE PROBLEM, THEN FOLLOW THE SOLUTION SUGGESTIONS. After every step re-try operating the changer to see if the problem has been solved.**

<b><i>Problem:</i></b>	<b><i>Solution:</i></b>
<p>A. <b>The phone card machine is completely dead.</b> (The green LED on the main logic board is not lit.)</p>	<ol style="list-style-type: none"> <li>1. Ensure the phone card machine is plugged in.</li> <li>2. Ensure the on/off switch is rocked to the (1) position (down).</li> <li>3. Unplug the female end of the line cord from the main logic board AC connector and plug it in again tightly.</li> <li>4. Measure the AC voltage at the outlet or check the breaker/fuse box. You can also plug another item into the AC wall outlet to ensure there is power present at the outlet.</li> <li>5. Inspect the AC line cord for cuts or abrasions.</li> <li>6. Check both fuses on the Main Logic Board.</li> <li>7. Replace the main logic board.</li> <li>8. Replace the line cord.</li> </ol>
<p>B. <b>The "Empty LED is lit.</b></p>	<ol style="list-style-type: none"> <li>1. Ensure the card dispenser is not out of cards.</li> <li>2. Check the card dispenser wire harness that extends from the back of the card dispenser to ensure it is plugged in firmly.</li> <li>3. Check the card output slot for foreign material.</li> <li>4. Replace the card dispenser.</li> <li>5. Replace the card dispenser wire harness.</li> </ol>
<p>C. The green LED on the main logic board is lit but the light up display never lights.</p>	<ol style="list-style-type: none"> <li>1. Bad 5 or 12vdc regulator on the main logic board.</li> <li>2. The card dispenser is shorted.</li> <li>3. Replace main logic board.</li> <li>4. Replace card dispenser.</li> </ol>
<p>D. The dollar bill acceptor accepts and stacks the money but the bill meter never counts up.</p>	<ol style="list-style-type: none"> <li>1. Check continuity and for pin damage to the blue and yellow wires on the validator harness.</li> <li>2. Replace the validator wire harness.</li> <li>3. Replace the validator.</li> </ol>
<p>F. The dollar bill acceptor stacks the bills, the meter counts up, but the card dispenser does not pay out.</p>	<ol style="list-style-type: none"> <li>1. Ensure the dip switch settings are still correct.</li> <li>2. Check the continuity of the brown and purple wires on the card dispenser wire harness.</li> <li>3. The card dispenser is jammed. Go to pg. 6. To un-jam the card dispenser.</li> <li>4. Replace the card dispenser wire harness.</li> </ol>
<p>G. Bill Validator will not pull in the bill and the "Empty" LED is not lit.</p>	<ol style="list-style-type: none"> <li>1. Ensure that the red Validator status LED is on steady.</li> <li>2. Check for blockage in the front of the bill Validator by removing the lower housing.</li> <li>3. Check for customer screwdriver prying or pocket knife gouges in the plastic which may cause the bill to stop and not go in. If you find some, use emery cloth and sand them down until smooth again.</li> <li>4. Replace Bill Validator.</li> </ol>

## TROUBLESHOOTING GUIDE

**TO USE THE TROUBLESHOOTING GUIDE, MATCH UP THE PROBLEM, THEN FOLLOW THE SOLUTION SUGGESTIONS. After every step re-try operating the changer to see if the problem has been solved.**

<b><i>PROBLEM:</i></b>	<b><i>SOLUTION:</i></b>
H. The dollar bill acceptor pulls in the bill slightly then rejects it.	<ol style="list-style-type: none"> <li>1. Clean the validator. (pg. 9)</li> <li>2. Remove the lower housing (pg. 11) of the dollar bill acceptor. Ensure the center wheel spins freely. Push straight down on it slightly to loosen.</li> </ol>
I. The dollar bill acceptor red status LED flashes a "5" error code.	<ol style="list-style-type: none"> <li>1. Clean the validator optic LED's. (See pg. 7)</li> <li>2. Ensure that all the wire harness plugs are plugged firmly into their white female sockets.</li> <li>3. Turn to the back page of this manual and check for a Coin Acceptors branch in your area to repair your dollar bill acceptor.</li> </ol>
J. The dollar bill acceptor red status LED flashes a "6 or 7" error code.	<ol style="list-style-type: none"> <li>1. Take the bill stacker off the dollar bill acceptor. Cycle the power on / off using the switch on the main logic board and coast the silver push bar so that it stops in its fully extended position. Blow out the area behind the push bar with high pressure or canned air. Concentrate on the encoder wheel in the area top center behind the push bar.</li> <li>2. Turn to the back page of this manual and check for a Coin Acceptors branch in your area to repair your dollar bill acceptor.</li> </ol>
K. The dollar bill acceptors red status LED is on steady but it still will not accept the bill.	<ol style="list-style-type: none"> <li>1. Pull out the lower housing, see page 8, and look for something obstructing the bill path. (I.e. gum; paper tickets, cards, etc.)</li> <li>2. Look inside the Plexiglas case on the side of the dollar bill acceptor. Ensure that all the wire harness plugs are plugged firmly into their white female sockets.</li> </ol>
L. The red "empty" LED on the outside of the phone card machine is on, the red status LED on the main logic board is flickering on and off normally, and the card dispenser is full of cards.	<ol style="list-style-type: none"> <li>1. Ensure the card dispenser is not out of cards.</li> <li>2. Check the card dispenser wire harness that extends from the back of the card, ensure it is plugged in firmly.</li> <li>3. Ensure the silver armature lever below the cards has not broken off.</li> <li>4. Replace the card dispenser.</li> <li>5. Replace the card dispenser wire harness.</li> </ol>
<b>FOR TECHNICAL SERVICE OR TO OBTAIN A RETURN AUTHORIZATION NUMBER CALL (888) 741-9840</b>	<b><u>ANY REPAIR RETURNED WITHOUT A RETURN AUTH. # WILL BE REFUSED!</u></b>

## PARTS LIST FOR THE AC502

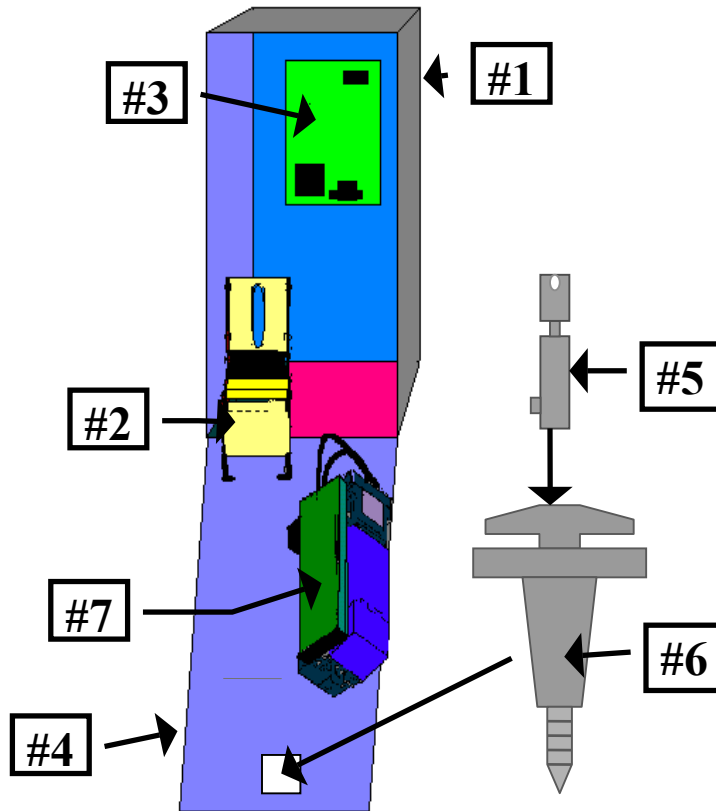

### AC502 PARTS LIST (SHOWN ABOVE)

1. **AC5019** - CABINET COMPLETE W/ COIN CUP (#2) & LOCK BRACKET (#3).
2. **AC5041** - ASAHI SEIKO CD200 CARD DISPENSER.
3. **AC2063.1** - MAIN LOGIC BOARD.
4. **AC1083** - FULL FACE LEXAN FRONT.
5. **AC1093** - LOCK AND KEY
6. **AC5080** - SCREW-IN T-HANDLE.
7. **AC9001.1** - COINCO BILL VALIDATOR.

### AC502 OPTIONAL PARTS LIST (ITEMS NOT SHOWN.)

- AC5043.1**- CARD EXTENSION (170 CARDS)
- AC5025** - LIGHT-UP DOME TOP
- AC1091** - TILT ALARM ONLY
- AC5071** - BASE (PEDESTAL)
- AC5071.1**- BASE PLATE
- AC5062** - VOICE BOARD W / SPEAKER

## COINCO PARTS LIST

### **MOUNTING ASSEMBLY PARTS BREAKDOWN**

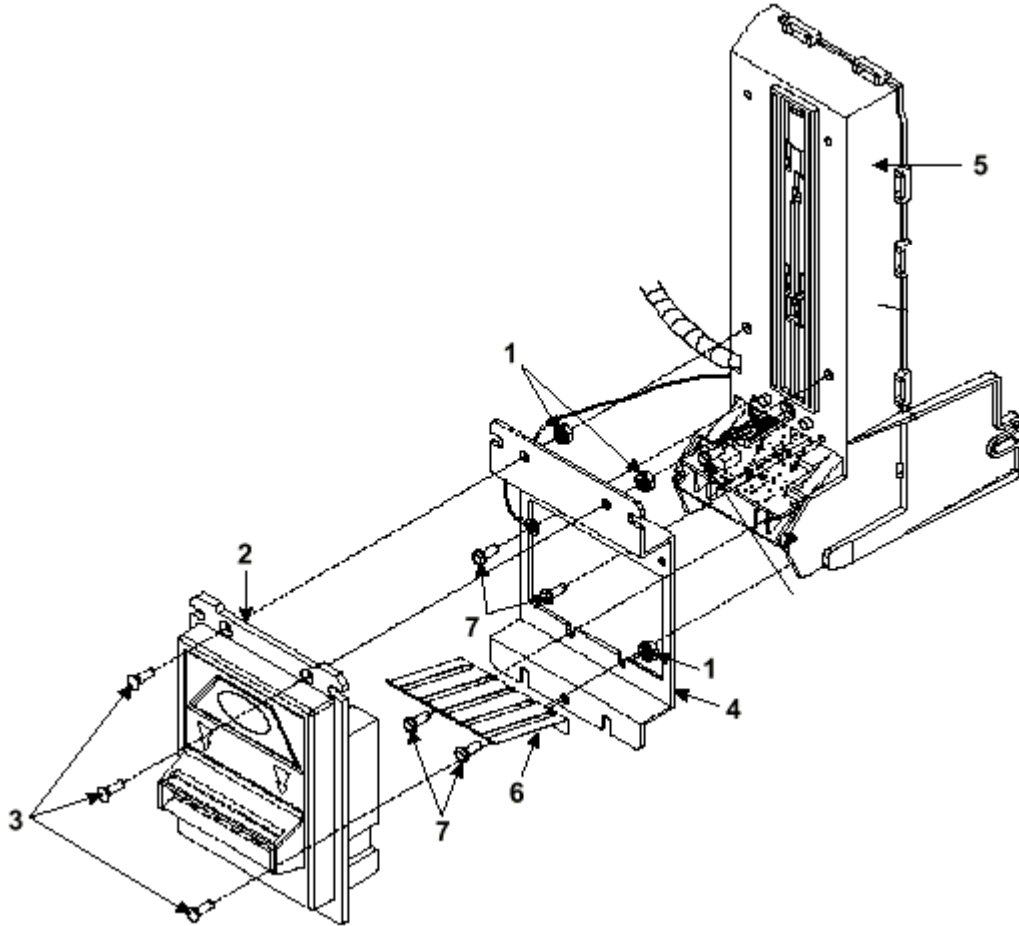

<u>PICTURE #</u>	<u>PART #</u>	<u>DESCRIPTION</u>
#1	MP90-1-1	Machine Screw
#2	MP91-1-2	"Snack Mask" Black Plastic
#3	MP90-1-3	Machine Screw
#4	MP90-1-4	Main Frame, Plastic
#5	MP91-1-5	Mask Gold Mounting Bracket
#6	MP90-1-6	Bill grounding spring
#7	MP91-1-7	Machine Nut

## COINCO PARTS BREAKDOWN

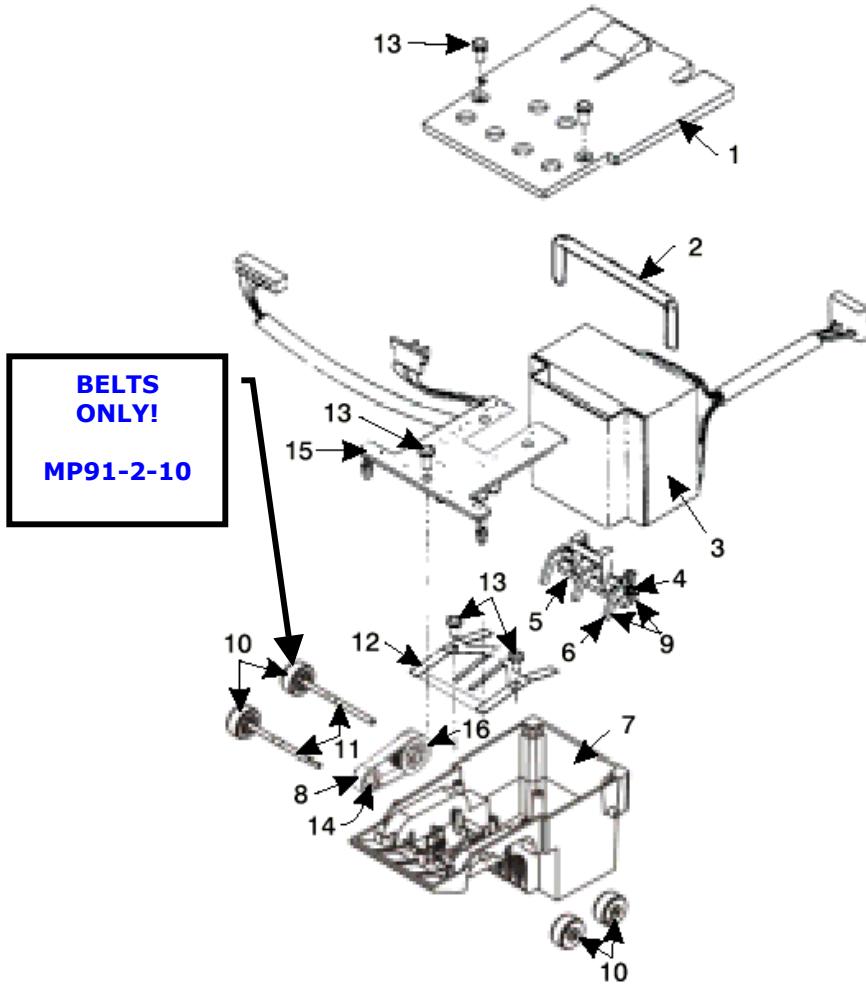

<u>PICTURE #</u>	<u>PART #</u>	<u>DESCRIPTION</u>
#1	MP90-2-1	Bottom Lower Housing Cover
#2	MP90-2-2	Transformer holding hose
#3	MP90-2-3	120VAC Transformer
#4	MP90-2-4	Lower Spring, Anti-Cheat Lever
#5	MP91-2-5	Lower Mounting, Anti-Cheat Lever
#6	MP90-2-6	Lower Anti-Cheat Lever
#7	MP90-2-7	Lower Housing Assembly, Complete
#8	MP90-2-8	Belt, Center
#9	MP90-2-9	Lower Anti-Cheat Assembly, Complete
#10	MP90-2-10	Plastic Wheels & Rubber Belts
<b>#10</b>	<b>MP91-2-10</b>	<b>Rubber Belts ONLY (Each)</b>
#11	MP90-1-11	Shaft, Drive
#12	MP90-2-12	Spring, MAG
#13	MP90-2-13	Screw, #4, Plastic
#14	MP90-2-14	Roller, Idler
#15	MP91-2-15	Sensor Board, Lower
#16	MP91-2-16	Pulley & Hub Assembly, Complete

## COINCO PARTS BREAKDOWN

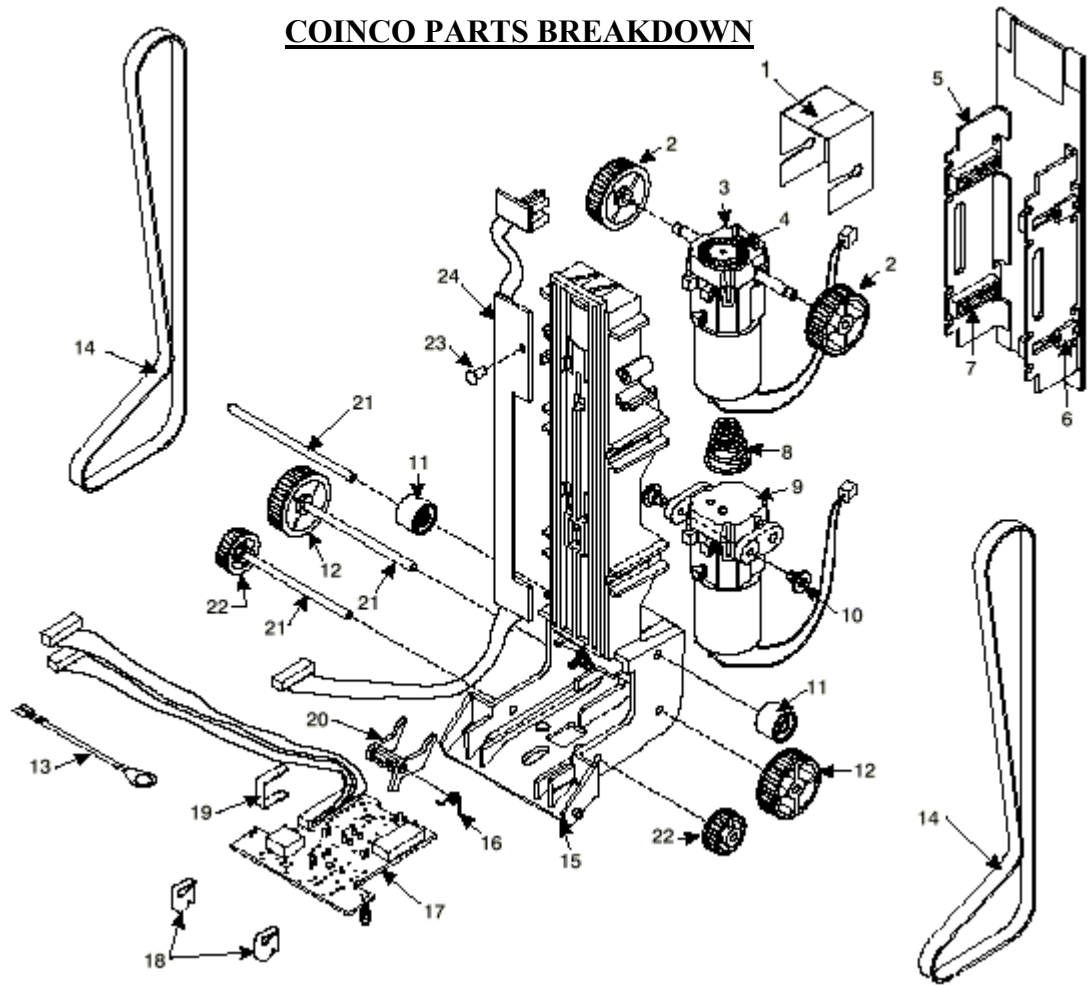

<u>PICTURE #</u>	<u>PART #</u>	<u>DESCRIPTION</u>
#1	MP90-3-1	Dust Cover
#2	MP90-3-2	Upper Transport & Hub Assembly, Complete
#3	MP91-3-3	Motor, Transport & Gear Assembly Complete
#4	MP90-3-4	Wheel, Encoder
#5	MP90-3-5	Stacker, Push-Plate Assembly
#8	MP90-3-8	Spring, Belt Tension
#9	MP90-3-9	Motor, Stacker Assembly Complete
#10	MP90-3-10	Pulley, Idler
#11	MP90-3-11	Lower Transport Pulley & Hub Assembly
#13	MP90-3-13	Belt, Upper Housing
#14	MP90-3-14	Frame, Upper Housing
#15	MP91-3-15	Sensor Board, Upper Housing
#16	MP90-3-16	Upper Board Clip
#17	MP90-3-17	Wire Clip
#18	MP90-3-18	Shaft, Pulley
#19	MP90-3-19	Shaft, Wheel
#21	MP90-3-21	Board, Stacker

**COINCO PARTS BREAKDOWN**

**INTERMEDIATE FRAME ASSEMBLY**

MP90-4-IF

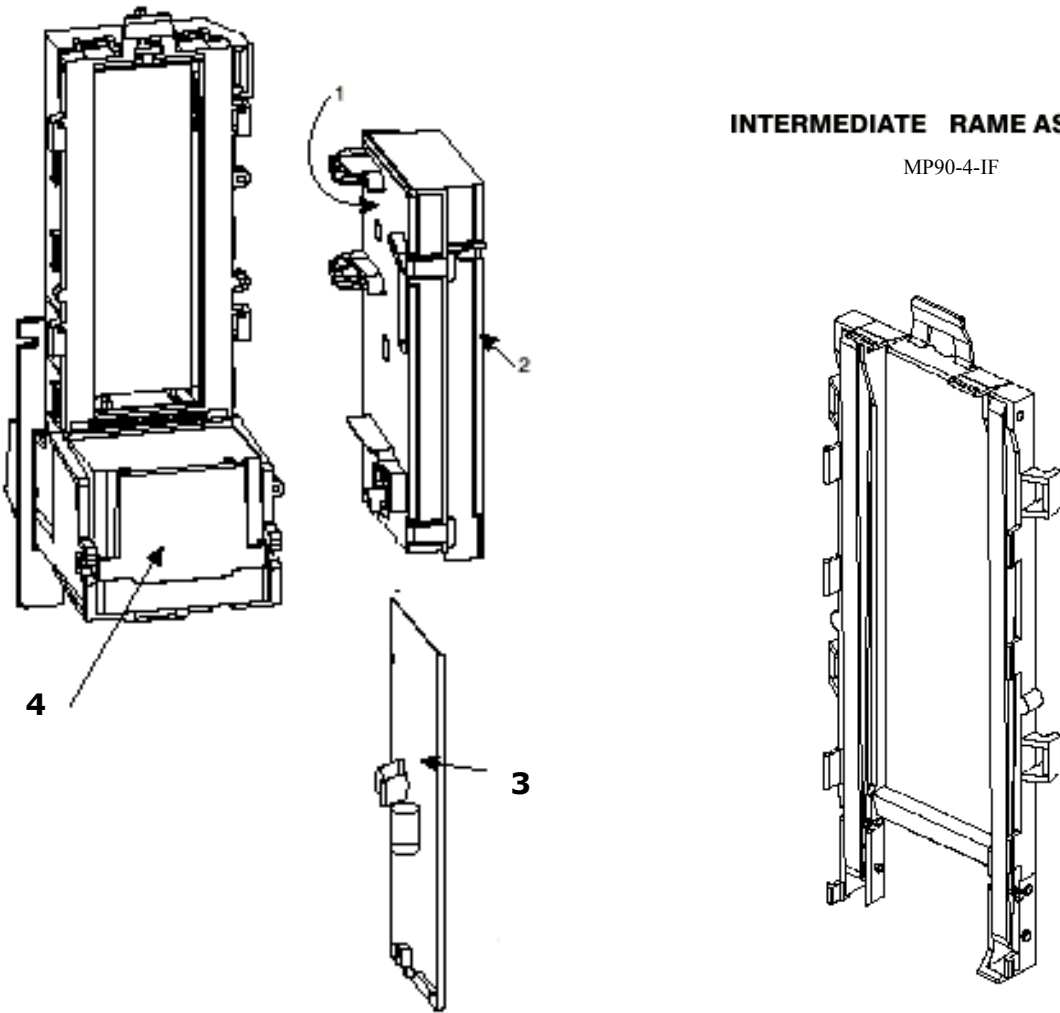

<b><u>PICTURE #</u></b>	<b><u>PART #</u></b>	<b><u>DESCRIPTION</u></b>
#1	MP90-4-1	Lid, Logic board Box
#2	MP91-4-2	Body, Logic board Box
#3	MP90-4-3	Main Logic Board
#4	MP90-4-4	Sticker, Serial Number / Warranty
#5	MP90-4-IF	Intermediate Frame with Bearings



## 8. PARTS LISTING

Item No.	Parts Description	Part Number
37	Sensor Bracket .....	CDS204P010028
38	Photo (Opto) Sensor .....	CDS204P010027
39	Discharge Roller .....	CDS204P010039
40	Discharge Roller Shaft .....	CDS204P010040
41	Screw, M3 x 4 (Set) .....	S3004S99
42	Feeding Roller Assy. ....	CDS204P010042
43	Shut-off Lever .....	CDS204P010030
44	Sensor Spring .....	CDS204P010031
45	Shut-off Lever Weight.....	CDS204P010032
46	Support Bar.....	CDS204P010046
47	E Ring #2.5 .....	W2500ER99
48	Tension Roller .....	CDS204P010048
49	Tension Lever .....	CDS204P010049
50	Tension Lever .....	CDS204P010047
51	MXL Geared Pulley (Z = 26).....	CDS204P010051
52	MXL Geared Pulley (Z = 30).....	CDS204P010052
53	MXL Geared Pulley (Z = 32).....	CDS204P010053
54	MXL Geared Pulley (Z = 18).....	CDS204P010050
55	MXL Geared Belt (Z = 87).....	CDS214P010034
56	MXL Geared Belt (Z = 95).....	CDS104P010041
57	E Ring #2 .....	W2000ER99
58	Side Plate (R) Assy. ....	CDS204P010002
59	Sensor Lever Weight.....	CDS204P010059
60	Screw, M3 x 5 .....	S3005RHSF
61	Empty Sensor Lever .....	CDS204P010061
62	Spring Pin, 2.5 x 8 .....	CDS204P010062
63	DC Solenoid, 24 VDC/12VDC .....	CDS204P010063
64	Clutch Lever .....	CDS204P010064
65	Nut, M3.....	N3000HX99
66	Solenoid Bracket .....	CDS204P010066
67	Control Board Insulator.....	CDS204P010067
68	(CD-9603) Control Board (CD-200) .....	CDS204P010603
	(CD-9603) Control Board (CD-1000) .....	CDS104P010603
	(CD-9102) Control Board (CD-1000,24V).....	CDS204P010625
	(CD-9102) Control Board (CD-1000,24V).....	CDS104P010625
	(CD-9102) Control Board (CD-200,12V).....	CDS203P010625
	(CD-9102) Control Board (CD-1000-12V).....	CDS203P010625

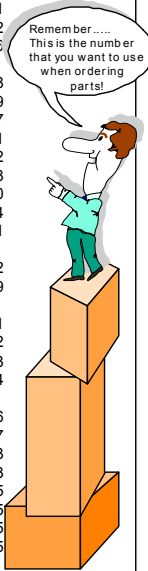

## 8. PARTS LISTING

Item No.	Parts Description	Part Number
1	Side Plate (L) Assembly .....	CDS204P010001
2	Screw, M2.6 x 6 .....	S2606RHSF
3	Screw, M3 x 5 .....	S3005RHSF
4	Flange Bushing .....	CDS204P010005
5	E ring #4 .....	W4000ER99
6	Screw, M3 x 5 SHCS .....	S3005HH99
7	Adjusting Plate .....	CDS204P010038
8	Screw, M3 x 6 (Set) .....	S3006SS99
9	Screw, M3 x 6 .....	S3006RHSF
10	Collar, 3 x 4 x 2.5 .....	CDS204P010003
11	Chain Assembly .....	CDS204P010004
12	Weight .....	CDS204P010045
13	Screw, M3 x 3 .....	S3003RHSF
14	Lock Plate Spring .....	CDS204P010006
15	Stopper Plate .....	CDS204P010015
16	Clutch Shaft .....	CDS204P010016
17	Screw, M2.6 x 4 .....	S2604RHSW
18	Spring Plate .....	CDS204P010017
19	Clutch Spring .....	CDS204P010018
20	Clutch Pin .....	CDS204P010019
21	Clutch Roller .....	CDS204P010020
22	Return Spring .....	CDS204P010021
23	Driving Cam .....	CDS204P010022
24	Driving Pin .....	CDS204P010023
25	Screw, M3 x 8 .....	S3008RHSF
26	Washer, 3 x 8 x 0.8 .....	W3008FW08
27	Guide Bracket .....	CDS204P010014
28	Guide .....	CDS204P010026
29	Spring Pin, 1.5 x 10 .....	CDS204P010013
30	Counter Turning Roller Assy .....	CDS204P010025
31	Discharge Roller Assy .....	CDS204P010024
32	Discharge Idle Guide .....	CDS204P010011
33	Shutter .....	CDS204P010007
34	Shutter Guide Shaft .....	CDS204P010010
35	Base Plate .....	CDS204P010035
36	Geared Motor .....	CDS204P010029

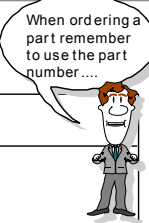



# CoinCo Authorized Service Centers

**Arizona**

3226 S. Fair Lane  
Tempe, AZ 85282  
Phone: 602-431-0632  
Chris Mattingly

**California**

11618 E. Washington Blvd.  
Suite # J  
Whittier, CA 90606  
Phone: 562-692-3059

**FLORIDA****Tampa**

6704 Benjamin Road  
Suite 200  
Tampa, FL 33634  
Phone: 813-249-7338  
Bob Wilcox

**Ft. Lauderdale**

American Changer  
1400 NW 65<sup>th</sup> Place  
Ft. Lauderdale, FL 33309  
888-741-9840  
RMA# Needed

**Georgia**

4215 Wendall Dr SW  
Suite # E  
Atlanta, GA 30336  
Phone: 404-691-2777  
Chuck Crockett

**Illinois**

862 Eagle Dr.  
Bensenville, IL 60106  
Phone: 630-860-2650  
Mike Durec

**Louisiana**

524 Elmwood Pkwy  
Suite 190  
Harahan, LA 70123  
Phone: 504-734-0280  
Frank Case

**Maryland**

6655 Amberton Drive  
Bay "L"  
Baltimore, MD 21227  
Phone: 410-379-2680  
Bill LeJune

**Massachusetts**

60 Prospect Street  
Waltham, MA 02453  
Phone: 781-894-4525  
Kevin Cole

**Missouri**

1236 Dielman Industrial CT  
St Louis, MO 63132  
Phone: 314-725-0100  
Charlie Pavia

**Ohio**

225 Corporate Court  
Suite I  
Fairfield, OH 45014  
Phone: 513-874-4460  
Joe Steddom

**TEXAS****Dallas**

3031 Quebec Street  
Suite 115  
Dallas, TX 75247  
Phone: 214-638-3970

**Houston**

2500 Central Parkway  
Suite "K"  
Houston, TX 77092  
Phone: 713-683-6558  
Steve TenBarge

**Washington**

1020 Industrial Drive  
Bldg. 32  
Seattle, WA 98188  
Phone: 206-575-1999  
Carl Goodson